

Long Period Grating Sensor to monitor Fuel Quality

Rosane Falate, José Luís Fabris, Márcia Müller and Hypolito José Kalinowski

Centro Federal de Educação Tecnológica do Paraná

Av. Sete de Setembro, 3165 – 80230-901 Curitiba, Brazil

e-mail: rfalate@cefetpr.br

We describe the production and characterisation of Long Period Gratings in fibre optics. The gratings are written in standard single-mode fibre using the electrical arc technique, while their transmission spectrum is used to control the grating length. Optical characterisation and wavelength dependence with temperature and refractive index of the external medium are shown. An application of the LPG as a sensor to monitor the fuel quality (Brazilian standard mixture of ethanol and gasoline) is presented.

1 Introduction

Fibre optic gratings or Fibre Bragg Gratings (FBG) were first reported in 1978 by Hill *et al*¹. However, such devices only attracted the researcher's attention² in 1989, when new production techniques allowed their use with optical communication wavelengths. Several methods exist for FBG production, among them the direct phase mask writing and phase mask interferometers³ stands out.

A new class of fibre gratings called Long Period Grating (LPG) was demonstrated by Vengsarkar *et al*⁴ in 1996. The name is due to the refractive index change periodicity from 100 to 700 μm , about 100 times larger than the values employed for FBG formation. This difference makes possible the use of amplitude masks instead of phase masks, resulting in lower manufacturing costs when compared to the FBG production's costs. Besides this, the LPG present other surpassing characteristics such as low insertion losses, sensibility to the surrounding medium refractive index (without etching the cladding to access the core's evanescent field), and a high sensitivity to changes in physical external parameters⁵. These features made the LPG outstanding devices for applications such as band rejection filters⁴ and gain equalising filters⁶ in optical communications, beyond its wide applicability as a fibre optic sensor^{6,7}.

In this work we report the results concerning the production and characterisation of long period gratings in standard telecommunication fibre optics. The behaviour of the LPG is shown for changes in the temperature and in the refractive index of the external medium. We also point to the prospect of using the device as a fuel quality control sensor, measuring the refractive index of a mixture of ethanol and gasoline. In Brazil this mixture has legal validity for an ethanol (distilled from sugar cane) proportion up to 24%. However, as the ethanol has a lower price (about 60%) than gasoline, a common malpractice is to increase ethanol concentration in the mixture that is sold to car owners. Procedures to verify the contents of ethanol in the mixture are required to assure the legal limit and to protect consumer's rights. Although we describe that particular sensor application, its use can be extended to any other kind of contaminant in the gasoline mixture, including other hydrocarbon based products that enter in the final composition of the commercial gasoline, if they change the refractive index of the mixture.

2 Theory and Experiments

Theory

Long period gratings are fibre optics based devices made up of periodic changes in the core's refractive index. The LPG operates by coupling the fundamental core mode to the co-propagating cladding modes. Standard Bragg gratings couple the fundamental mode with a counter-propagating mode in the core, and the large change in the wave vector implies short periods for the gratings. For a LPG, the small difference between the co-propagating wave vectors requires longer spatial periods in the index modulation. For a grating periodicity Λ , the phase matching condition is⁴:

$$\beta_{co} - \beta_{cl}^m = \frac{2\pi}{\Lambda} \quad (1)$$

where β_{co} e β_{cl}^m are, respectively, the propagation constants of the core mode and the m-th order cladding mode. Since the propagation constants depend on the effective refractive index for a specific wavelength, Eq. 1 can be written as:

$$\lambda_m = (n_{eff_co} - n_{eff_cl}^m) \Lambda \quad (2)$$

where λ_m is the peak wavelength of the resonance between the core mode and the cladding mode, n_{eff_co} and $n_{eff_cl}^m$ are, respectively, the effective refractive index of the core mode and of the m-th order cladding mode. Since the interaction of the guided mode in the fibre occurs with a cladding mode, which is strongly affected by fibre imperfections, micro and macro bending and by the boundary condition at the cladding-external medium interface, light coupled from the core mode leaks out the fibre, leaving several transmission dips in the transmission spectrum, each one corresponding to a specific modal coupling governed by Eq. 2.

LPG are very useful as sensors when the refractive index of the external medium changes. If the parameter to be measured affects the refractive index, this will also change the matching condition expressed by Eq. 2 and will lead to a wavelength shift of the resonance dip in the LPG transmission spectrum. That occurs because the effective indexes of cladding modes are dependent on the refractive index of the core, cladding and external medium. For comparison, in the case of Bragg gratings the effective index of the mode in the fibre's core depends on the core and cladding refractive index, so that a change on the external medium index only is perceived when the cladding is almost entirely removed, to expose the evanescent field of the core mode to the external index. As the LPG has greater sensitivity to changes in the external medium^{4,5,8}, their use as sensors of refractive index changes is far more interesting than sensors based on Bragg gratings. Another advantage is that the cladding does not need to be removed, a fact that drastically affects the mechanical properties of the fibre⁵.

For temperature changes, the grating response analysis is done by differentiating Eq. 2 regarding to the temperature, and the resonance dip wavelength follows⁸:

$$\frac{d\lambda_m}{dT} = \Lambda \left[\frac{d(n_{ef_co} - n_{eff_cl}^m)}{dT} \right] + (n_{eff_co} - n_{eff_cl}^m) \left(\frac{d\Lambda}{dT} \right) \quad (3)$$

From this equation it can be seen that there are two factors which lead to the dip wavelength displacement: the thermo-optic effect and the thermal expansion of the fibre. The former is related to the grating pitch and to the cladding mode order, ranging from 2.0×10^{-5} to $4.0 \times 10^{-5} \text{ } ^\circ\text{C}^{-1}$ for Corning SMF-28 fibres⁹, and the latter to the thermal expansion coefficient $\alpha = 0.5 \times 10^{-6} \text{ } ^\circ\text{C}^{-1}$ for fused silica¹⁰. As a result, the thermal grating sensibility is mainly determined by changes in the core and cladding refractive indexes.

LPG production

The LPG set-up production is shown in Fig.1, which uses a technique similar to that described by¹¹. A bare standard communication fibre (ABCXtal SMD) with its protective coating removed is inserted between the electrodes of a commercial splice machine (Siemens S46999-M7-A71). A small weight (mass = 17.58 g) is lifted up in one of the fibre's extremities to keep a constant longitudinal tension. The other fibre extremity is connected to a computer controlled $5 \text{ } \mu\text{m}$ resolution translation stage. An electrical arc (12 mA, 0.5 sec) is applied with the splicing machine, and after each discharge the fibre is shifted by the required grating period Λ . After a suitable number of point-to-point discharges, a periodic pattern is engraved in the fibre's refractive index profile, due to heating activated process. An optical reading set-up is used during the writing process to monitor the transmission spectrum through the fibre. When the measured spectrum shows adequate characteristics to the intended application, the process is interrupted. Usually 40-70 points were necessary to form a grating described in this work. The advantage of using the electrical arc is that no special fibres (hydrogenated or pre-sensitised) are required.

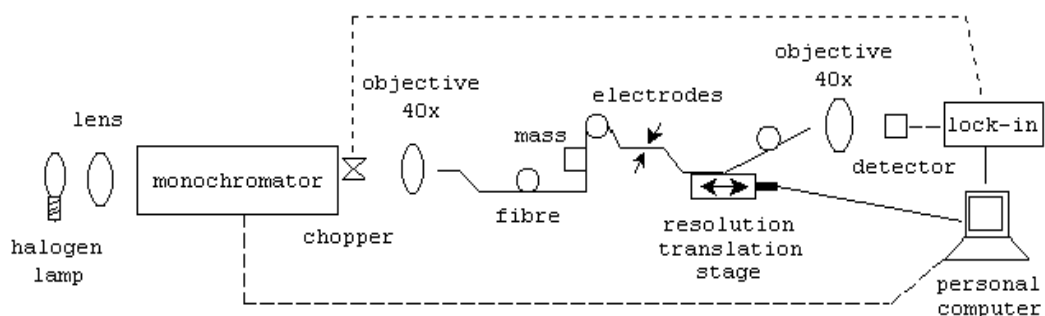

Fig.1 Set-up used for the LPG production and characterisation.

Measurements for the characterisation of the LPG and to determine its sensitivity to changes in the parameters of the external medium are made using a halogen lamp, whose light is focused on the entrance slit of a monochromator (Sciencetech 9050). After the exit slit, light is modulated by a mechanical chopper and launched into the fibre using a 40X microscope objective. The light on the fibre's output is collected by another 40X objective onto an InGaAs photo detector. The electrical signal from the photo detector is fed to a lock-in amplifier (Stanford Research Systems SR830), synchronised to the chopper's modulating frequency. A personal computer controls the fibre positioning system¹², the monochromator grating position and collects the resulting data through an Analogue to Digital Converter card. Fig. 2 shows the grating growth from 20 to 40 applied electrical arcs, for a grating periodicity of 649 μm .

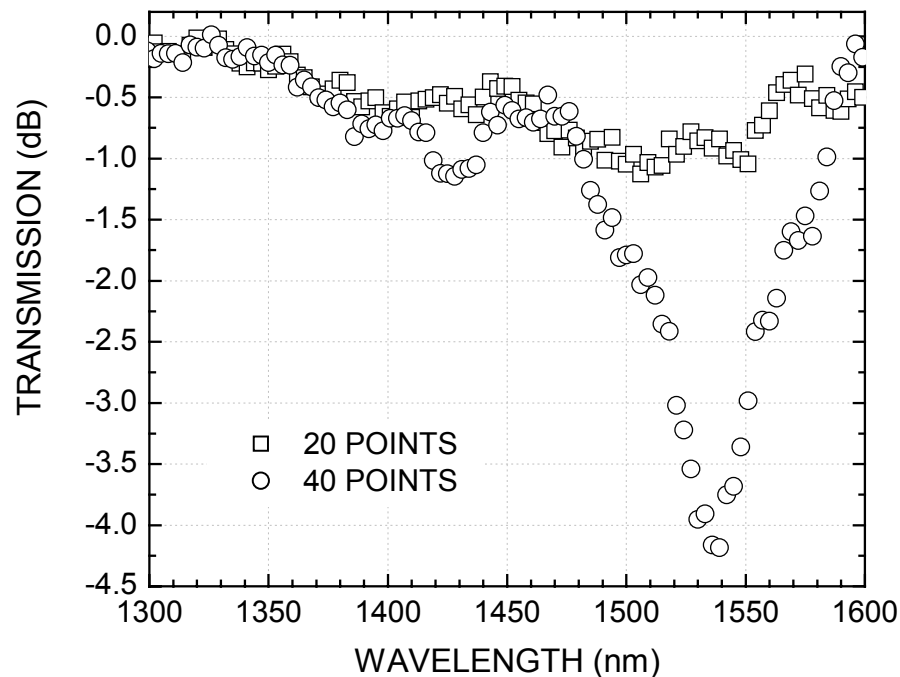

Fig. 2 Evolution of the LPG spectrum during the writing process, for 20 and 40 points of the applied electrical arc.

3 Results and Discussion

To apply the produced LPG for sensing purposes, it is characterised when the temperature in the

external medium changes. In order to assure that no strain resulting from thermal expansion could affect the measurements, the fibre was kept loose under a glass plate. To keep the transducer without bending, the two fibre sides close to the engraved part pass through two hollow glass tubes. The thermal behaviour for the main attenuation dip (1540 nm at room temperature) is shown in Fig. 3 for temperatures ranging from 21 to 58 °C. The spectra are taken with a 1 nm resolution both for increasing and decreasing temperatures, resulting in angular coefficients of 0.103 nm/°C for the former and 0.099 °C for the latter process. No significant hysteresis is found for the temperature range analysed.

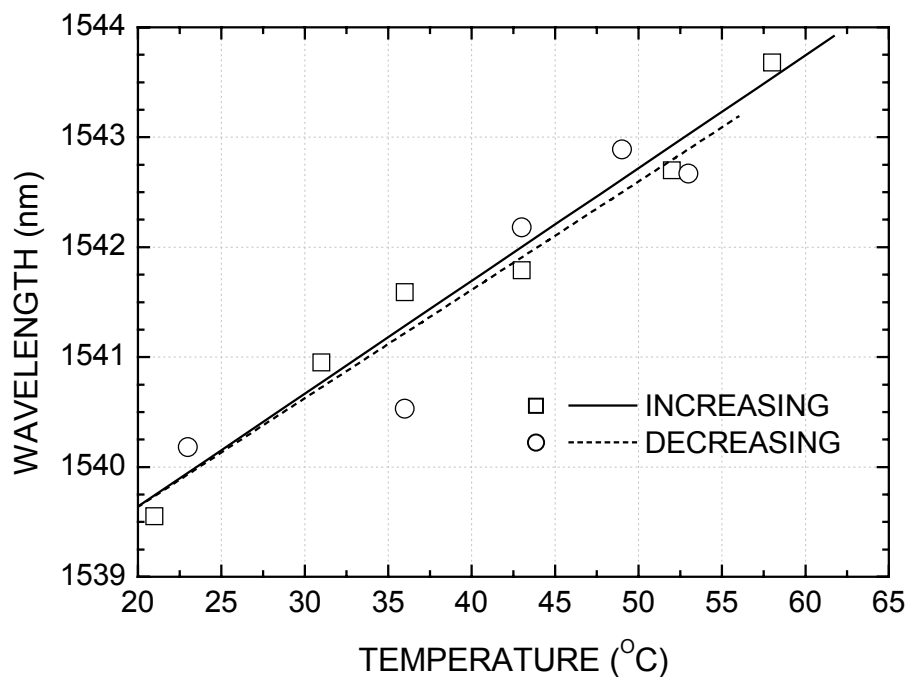

Fig. 3 Thermal behaviour of the LPG attenuation dip wavelength for increasing and decreasing temperatures. Symbols: experimental determination; lines: best fit.

The response of the sensor to the external medium's refractive index is measured as follows. First the fluid is laid over the fibre (covering all the region where the LPG resides) and a cover glass is used to insure that the LPG remains inside the liquid during all the measurements. Then transmission spectra are recorded as a function of the liquid mixture, using the same equipment as described in the previous section.

Initially a few calibration measurements were taken using mixtures of several fluids whose refractive index are known. Results for a grating with 40 periods (pitch of 649 μm) are shown in Fig. 4. It can be seen that the larger change in the resonant wavelength occurs when the refractive index of the external medium is close to the cladding refractive index^{5,13}. A spectral shift of 7 nm in the refractive index range from 1.333 and 1.426 is obtained¹⁴.

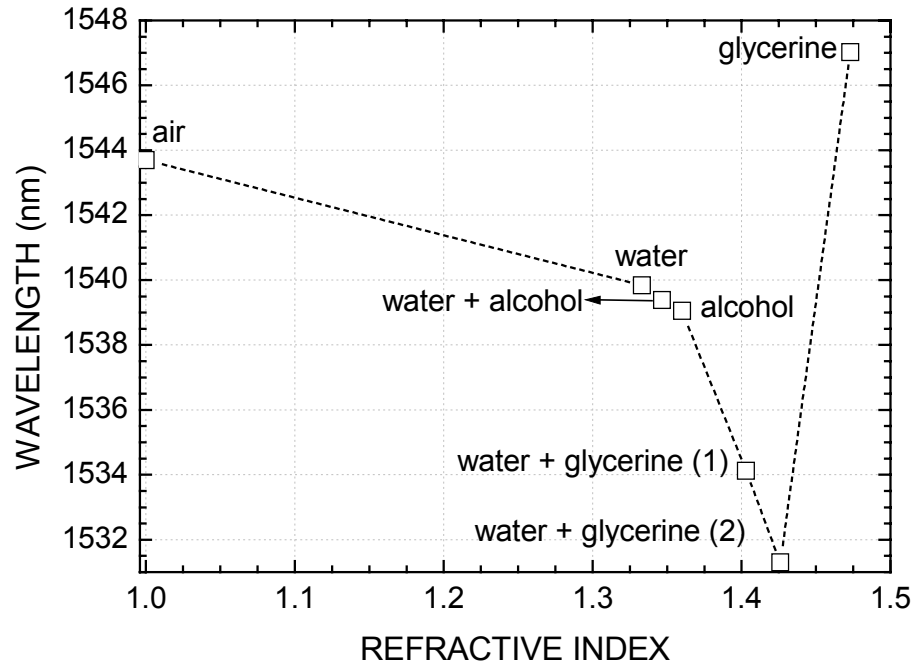

Fig. 4 Peak position of the main attenuation dip in the transmission spectrum of an LPG ($\Lambda = 649 \mu\text{m}$, 40 points) as a function of the refractive index of the external medium, in the range between 1.000 and 1.426. The lines are only guides to the eye.

Apart from the wavelength shift when the refractive index of the external medium changes, LPGs also present a reduction in the peak attenuation of the resonance band¹³. This can also be seen in our measurements, as shown in Fig. 5, where there is a comparison between the spectra taken with pure water and the spectra taken with a mixture of water and glycerine covering the fibre. The later mixture has a refractive index that is closer to the cladding index, causing greater mismatch between the core and cladding modes. This fact reduces the power coupled from core to cladding modes.

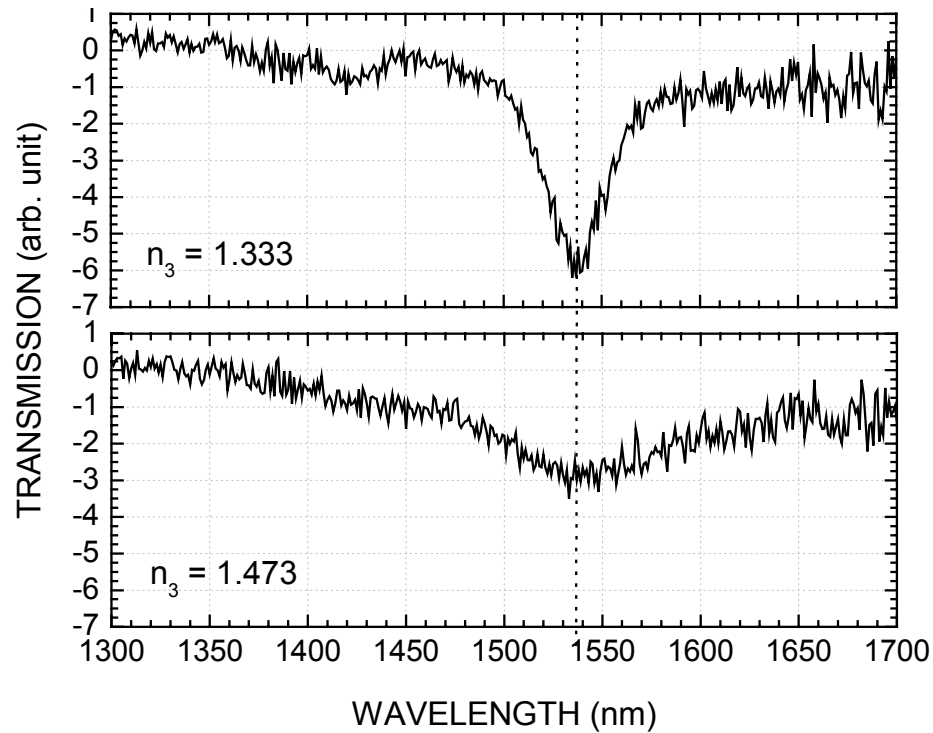

Fig. 5. Transmission spectra of the same LPG comparing the attenuation dip for two different refractive indexes of the external medium: water (top) and a mixture of water and glycerine (bottom). The refractive index of the external medium is shown in the lower left corner of each graph.

Fig. 6 shows the peak position of the resonant band in the transmission spectrum of the same LPG when the fibre optics is immersed in a mixture of ethanol and commercial gasoline (Brazilian standards). The initial point in that graph corresponds to the legal proportion of 24 % of ethanol in the mixture. Higher ethanol concentrations are obtained by the proper mixture of pure ethanol to the legal gasoline, tracking the alcohol proportion during the whole process. Using the pure ethanol as external medium is possible to obtain the point corresponding to the concentration of 100 %. The graph shows the sensitivity of the LPG when used as a sensor for the proportion of the mixture, based on the fact that the refractive index of a mixture of two liquids has a value depending on their respective concentration¹⁵ (parts per volume). It can be seen on Fig. 6 that the sensor is useful to determine ethanol proportions (in

volume) even higher than 60 %, although the region with greater sensitivity, where the slope is approximately linear, lies between 24 % and 49 % (see insert in that figure). This region is particularly useful because most of the frauds and malpractice using higher concentration of ethanol are within such range (for higher concentrations the engine may not work properly, which attracts the attention of consumers). The best fitting slope in that linear region is 0.17 ± 0.02 nm/%. It is also important to notice that the absolute variation of the peak position of the resonance band is around 4.5 nm in that region, a dynamic range that assures the possibility of even better accuracy and resolution, when using LPG with narrower line widths. Another improvement that can be used to increase accuracy and resolution is the use of thermal annealed fibre to write the long period grating. It has been shown that fibres annealed by half an hour at 1050 °C can dramatically improve the resonance band in the transmission spectrum¹⁶ of LPG formed by the electrical arc process.

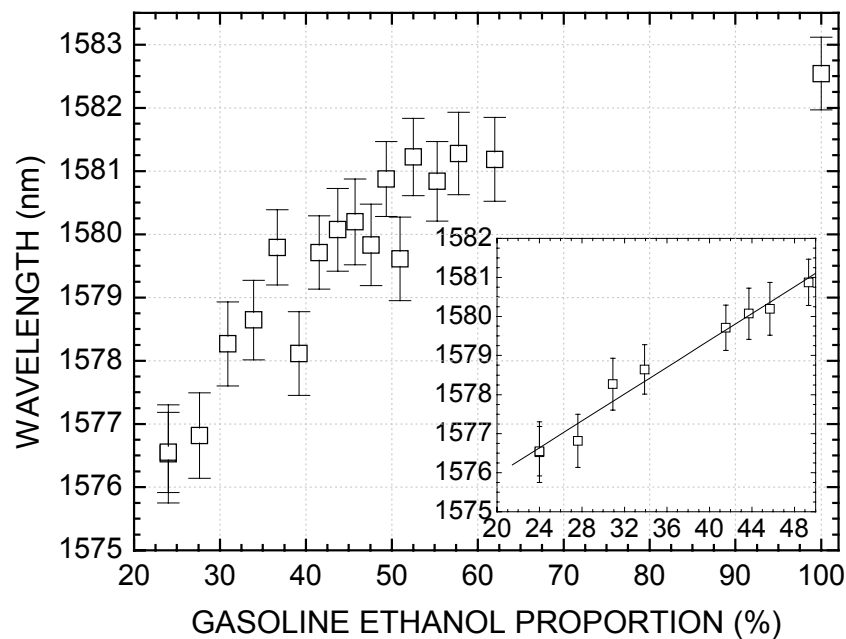

Fig. 6. Peak position of the resonance band in the transmission spectrum of the LPG as a function of ethanol proportion (in volume) between 24 and 100 %. The insert shows the region with higher sensitivity (24 and 49 %) that can be described by a linear relation with slope of 0.17 ± 0.02 nm/%.

4 Conclusion

We described the results obtained from point-to-point electrical arc discharge technique applied to LPG production in a standard communication fibre optics, as well as the experimental writing set-up. The main method advantage is that there is no need for expensive photosensitive fibres and UV or CO₂ lasers to produce the grating. The on-line spectrum observation during the writing process allows to obtain gratings with desired characteristics for each particular application.

Results from temperature measurements performed with the LPG showed sensibilities between 0.099 and 0.103 nm/°C for the temperature range from 21 to 58 °C. Measurement of ethanol proportion when mixed with gasoline is reported. Calibration of the process has been checked by the use of liquids with known refractive index. A spectral shift of 7 nm was obtained when the refractive index varied from 1.333 to 1.426. For the ethanol measurements the average sensitivity for the wavelength shift of the resonance band is 0.17 ± 0.02 nm/%, for the region where the ethanol proportion changed from 24 to 49 % in the mixture with gasoline. The process can be used with other hydrogen – carbon products that are also used in the gasoline and that can have fraudulent use.

Acknowledgements

Authors acknowledge financial support from CAPES, CNPq, CTPETRO and Fundação Araucária (Brazilian Agencies). This work has been partially done as an activity linked to the “Laboratório de Inovação em Tecnologia de Sensores – LITS” sponsored by “Paraná Tecnologia”. A patent application has been filled for the corresponding equipment and process.

References

- 1 Hill K. O., Fujii Y., Johnson D. C., and Kawasaki B. S., “Photosensitivity in optical fiber waveguides: Application to reflection filter fabrication”, *Appl. Phys. Lett.*, vol. 32, no. 10 (1978) 647-649.
- 2 Meltz G., Morey W. W., and Glenn W. H., “Formation of Bragg gratings in optical fibers by a transverse holographic method”, *Opt. Lett.*, vol. 14, no. 15 (1989) 823-825.
- 3 Othonos A., Kalli K., *Fiber Bragg Gratings: Fundamentals and Applications in Telecommunications and Sensing*. (Artech House, Norwood), 1999.

- 4 Vengsarkar A. M., Lemaire P. J., Judkins J. B., Bhatia V., Erdogan T., and Sipe J. E., "Long-Period Fiber Gratings as Band-Rejection Filters", *J. Lightwave Technol.*, vol. 14, no. 1 (1996)58-65.
- 5 Bhatia V., and Vengsarkar A. M., "Optical fiber long-period grating sensors", *Opt. Lett.*, vol. 21, no. 9 (1996)692-694.
- 6 Vengsarkar A. M., Pedrazzani J. R., Judkins J. B., Lemaire P. J., Bergano N. S. and Davidson C. R., "Long-period fiber-grating-based gain equalizers", *Opt. Lett.*, vol. 21, no. 5 (1996)336-338.
- 7 Falate R., "Produção e Caracterização de Redes de Período Longo para Aplicações em Sensoriamento", *Master's thesis, CEFET-PR (2002)*.
- 8 Abramov A. A., Eggleton B. J., Rogers J. A., Espindola R. P., Hale A., Windeler R. S., and Strasser T. A., "Electrically Tunable Efficient Broad-Band Fiber Filter", *IEEE Photon. Technol. Lett.*, vol. 11, no. 4 (1999)445-447.
- 9 Qin L., Wei Z. X., Wang Q. Y., Li H. P., Zheng W., Zhang Y. S., Gao D. S., "Compact temperature-compensating package for long-period fiber gratings", *Optical Materials*, vol. 14 (2000)239-242.
- 10 Yin S., Chung K.W., Zhu X., "A highly sensitive long period grating based tuneable filter using a unique double-cladding layer structure", *Optics Communications*, vol. 188 (2001)301-305.
- 11 Rego G., Okhotnikov O., Dianov E., and Sulimov V., "High-Temperature Stability of Long-Period Fiber Gratings Produced Using an Electric Arc", *J. Lightwave Technol.*, vol. 19, no. 10 (2001)1574-1579.
- 12 Fabris J. L., de Góes R. E., Falate R., and Müller M., "Sistema Integrado para Caracterização Ótica de Materiais", *Rev. Fis. Aplic. e Instr.*, vol. 14, no. 2 (1999)38-44.
- 13 Patrick H. J., Kersey A. D., and Bucholtz F., "Analysis of the Response of Long Period Fiber Gratings to External Index of Refraction", *J. Lightwave Technol.*, vol. 16, no. 9 (1996)1606-1612.
- 14 Falate R., Fugihara M. C., Müller M., Kalinowski H. J. e Fabris J. L., *Anais do X Simpósio Brasileiro de Microondas e Optoeletrônica*, (2002)79-82.
- 15 Bueno W., Boodts J. F. C., Degreve L., Leone F. A., *Química Geral*. (McGraw-Hill do Brasil, São Paulo), 1978, p. 19-33, 307-316.
- 16 Rego G., Sulimov V., Dianov E., Santos J. L., Salgado H. M., *in Física 2002, 13a Conferência Nacional de Física e 12o Encontro Ibérico para o Ensino de Física*, (2002)496-498.